

REFERENCE AMPLIFIER A500

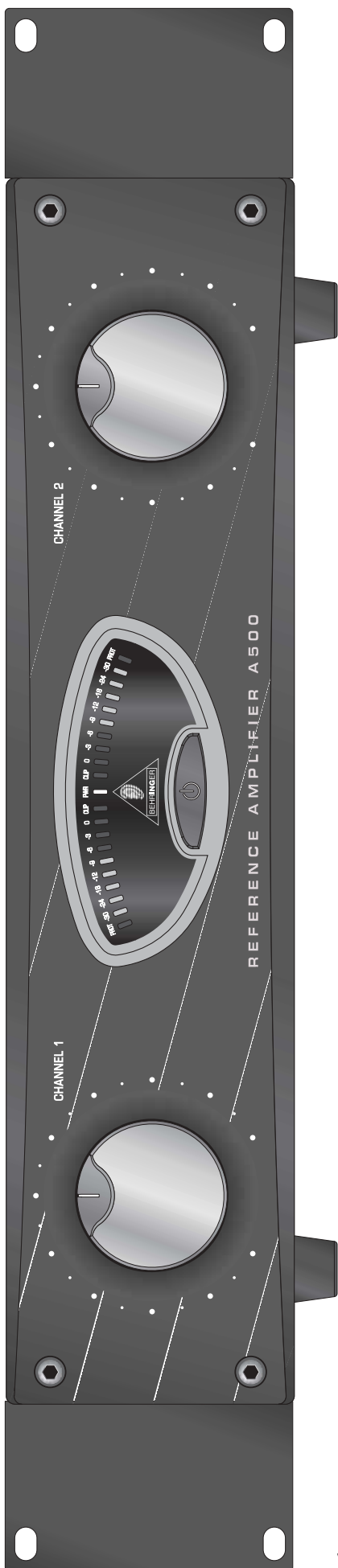

User's manual

Version 1.0 March 2005

ENGLISH

www.behringer.com



REFERENCE AMPLIFIER A500

IMPORTANT SAFETY INSTRUCTIONS



CAUTION: To reduce the risk of electric shock, do not remove the top cover (or the rear section). No user serviceable parts inside; refer servicing to qualified personnel.

WARNING: To reduce the risk of fire or electric shock, do not expose this appliance to rain and moisture. The apparatus shall not be exposed to dripping or splashing and no objects filled with liquids, such as vases, shall be placed on the apparatus.



This symbol, wherever it appears, alerts you to the presence of uninsulated dangerous voltage inside the enclosure—voltage that may be sufficient to constitute a risk of shock.



This symbol, wherever it appears, alerts you to important operating and maintenance instructions in the accompanying literature. Please read the manual.

DETAILED SAFETY INSTRUCTIONS:

- 1) Read these instructions.
- 2) Keep these instructions.
- 3) Heed all warnings.
- 4) Follow all instructions.
- 5) Do not use this apparatus near water.
- 6) Clean only with dry cloth.
- 7) Do not block any ventilation openings. Install in accordance with the manufacturer's instructions.
- 8) Do not install near any heat sources such as radiators, heat registers, stoves, or other apparatus (including amplifiers) that produce heat.
- 9) Do not defeat the safety purpose of the polarized or grounding-type plug. A polarized plug has two blades with one wider than the other. A grounding type plug has two blades and a third grounding prong. The wide blade or the third prong are provided for your safety. If the provided plug does not fit into your outlet, consult an electrician for replacement of the obsolete outlet.
- 10) Protect the power cord from being walked on or pinched particularly at plugs, convenience receptacles, and the point where they exit from the apparatus.
- 11) Only use attachments/accessories specified by the manufacturer.
- 12) Use only with the cart, stand, tripod, bracket, or table specified by the manufacturer, or sold with the apparatus. When a cart is used, use caution when moving the cart/apparatus combination to avoid injury from tip-over.



13) Unplug this apparatus during lightning storms or when unused for long periods of time.

14) Refer all servicing to qualified service personnel. Servicing is required when the apparatus has been damaged in any way, such as power supply cord or plug is damaged, liquid has been spilled or objects have fallen into the apparatus, the apparatus has been exposed to rain or moisture, does not operate normally, or has been dropped.

15) **CAUTION** - These service instructions are for use by qualified service personnel only. To reduce the risk of electric shock do not perform any servicing other than that contained in the operation instructions unless you are qualified to do so.

REFERENCE AMPLIFIER A500

REFERENCE AMPLIFIER A500

Professional 500-Watt Reference-Class Studio Power Amplifier

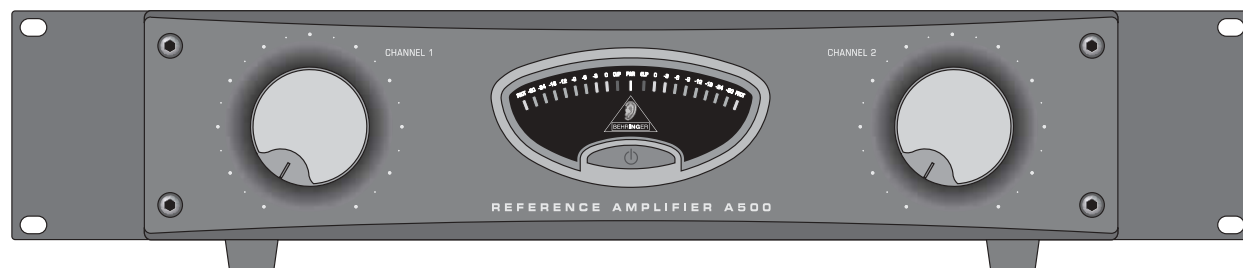

- ▲ Ultra-linear power amplifier for recording studios, post-production, live sound and HiFi application
- ▲ 2 x 230 Watts into 4 Ohms, 500 Watts into 8 Ohms in bridged mono operation
- ▲ Servo-controlled design can drive virtually any passive speaker such as studio monitors etc.
- ▲ Advanced convection-cooling for absolutely noise free and stable operation (no fan)
- ▲ Precise level meter and clip indicators for performance monitoring
- ▲ Input connections on balanced XLR, 1/4" TRS and RCA connectors
- ▲ Speaker outputs on professional "touch-proof" binding posts and 1/4" TS connectors
- ▲ Ultra-reliable Toshiba™ / Fairchild™ high-power transistors*
- ▲ Independent thermal overload protection with LED indicator for each channel automatically protects amplifier and speakers
- ▲ High-current toroidal transformer for absolute reliability and lowest noise interference
- ▲ High-quality components and exceptionally rugged construction ensure long life
- ▲ Conceived and designed by BEHRINGER Germany

* All Trademarks mentioned belong to their respective owners and are not affiliated with BEHRINGER®

REFERENCE AMPLIFIER A500

FOREWORD



Dear Customer,
welcome to the team of BEHRINGER users, and thank you very much for expressing your confidence in us by purchasing this power amplifier.

Writing this foreword for you gives me great pleasure, because it represents the culmination of many months of hard work delivered by our engineering team to achieve a very ambitious goal: to develop a studio power amplifier, whose sound and fetures leave no wishes open, delivering a product that

is suitable for nearly all applications, from the recording studio to setting up a P.A. system for small live events.

The task of designing the A500 certainly meant a great deal of responsibility, which we assumed by focusing on you, the discerning user and musician. Meeting your expectations also meant a lot of work and night shifts. But it was fun, too. Developing a product usually brings a lot of people together, and what a great feeling it is when all who participated in such a project can be proud of what they've achieved.

It is our philosophy to share our enjoyment with you, because you are the most important member of the BEHRINGER team. With your highly competent suggestions for new products you've made a significant contribution to shaping our company and making it successful. In return, we guarantee you uncompromising quality as well as excellent technical and audio properties at an extremely reasonable price. All of this will enable you to give free rein to your creativity without being hampered by budget constraints.

We are often asked how we manage to produce such high-quality devices at such unbelievably low prices. The answer is quite simple: it's you, our customers! Many satisfied customers mean large sales volumes enabling us to get better purchasing terms for components, etc. Isn't it only fair to pass this benefit on to you? Because we know that your success is our success too!

I would like to thank all of you who have made the A500 possible. You have all made your own personal contributions, from the developers to the many other employees at this company, and to you, the BEHRINGER user.

My friends, it's been worth the effort!

Thank you very much,

Uli Behringer

INDEX

1. INTRODUCTION	4
1.1 Before you get started	4
1.1.1 Shipment	4
1.1.2 Initial operation	5
1.1.3 Online registration	5
2. CONTROL ELEMENTS	5
2.1 The front	5
2.2 The back	6
3. APPLICATION EXAMPLES	7
3.1 Stereo operation	7
3.2 Mono-bridged mode	7
4. INSTALLATION	7
4.1 Installation in a rack	7
4.2 Connections	8
4.3 Audio connections	8
5. SPECIFICATIONS	8
6. WARRANTY	10

1. INTRODUCTION

By purchasing an A500, you have obtained a high-end reference amplifier. It was developed for professional use in recording studios, but at the same time it offers enough power reserves to be used in smaller live setups as well. Its rich list of features will make it a dependable part of your equipment with a broad spectrum of possible uses.

The A500 features special circuitry that protects your speakers from transients during start-up and your amp from overheating. The amp is not put at any risk even if there is a short on its outputs.

Various operating modes, such as parallel and mono mode, open up different possibilities for effective implementation with the rest of your audio equipment, leaving little to be desired.

Balanced inputs and outputs

Your BEHRINGER A500 features electronically servo-balanced inputs (exception: RCA connectors [6] and [7] are intended only for unbalanced connections). The automatic servo function recognizes when unbalanced jacks are connected and internally adjusts the nominal signal level so that no difference in the signal level between inputs and outputs exists (6 dB correction).

 **This manual first describes the terminology used, so that you fully understand the A500 and its functions. Please read the manual carefully and keep it for future reference.**

1.1 Before you get started

1.1.1 Shipment

Your A500 was carefully packed at the factory, and the packaging was designed to protect the unit from rough handling. Nevertheless, we recommend that you carefully examine the packaging and its contents for any signs of physical damage that may have occurred during transit.

REFERENCE AMPLIFIER A500

- 👉 If the unit is damaged, please do NOT return it to BEHRINGER. Instead, notify your dealer and the shipping company immediately. Otherwise, claims for damage or replacement may not be honored.
- 👉 Always use the original packaging to prevent damage during storage or transport.
- 👉 Make sure that no children are left unsupervised with the A500 or its packaging.
- 👉 Please ensure proper disposal of all packing materials.

1.1.2 Initial operation

Make sure there is enough space around the unit for cooling. To avoid overheating, please do not place your amplifier near radiators and other equipment emitting heat.

- 👉 Before plugging the unit into a power socket, please make sure you have selected the correct voltage!

The fuse compartment near the power plug socket contains three triangular markings. Two of these triangles are opposite one another. The voltage indicated adjacent to these markings is the voltage to which your unit has been set up, and can be altered by rotating the fuse compartment by 180°. **ATTENTION: This does not apply to export models that were manufactured only for use with 120 V, for example!**

- 👉 If you alter the unit's voltage, you must change the fuse accordingly. The correct value of the fuse needed can be found in the chapter "SPECIFICATIONS."
- 👉 Faulty fuses must be replaced with fuses of appropriate rating only! The correct value of the fuses needed can be found in the chapter "SPECIFICATIONS."

Power is delivered via the cable enclosed with the unit. All required safety precautions have been adhered to.

- 👉 Please keep in mind that all your equipment has to be grounded at all times. For your own protection, never change or disable the grounding on your equipment or on the cables! The unit should always be connected to the mains socket outlet with a protective earthing connection.

ATTENTION!

- 👉 High volume levels can damage your hearing and your speakers. Please turn down both volume controls to the minimum (all the way to the left) before you power up the amp. Always make sure you use appropriate volume levels.

1.1.3 Online registration

Please do remember to register your new BEHRINGER equipment right after your purchase by visiting www.behringer.com (alternatively www.behringer.de) and kindly read the terms and conditions of our warranty carefully.

Should your BEHRINGER product malfunction, our goal is to have it repaired as quickly as possible. To arrange for warranty service, please contact the retailer from whom the equipment was purchased. Should your BEHRINGER dealer not be located in your vicinity, you may directly contact one of our subsidiaries. Corresponding contact information is included in the original equipment packaging (Global Contact Information/European Contact Information). Should your country not be listed, please contact the distributor nearest you. A list of distributors can be found in the support area of our website (www.behringer.com/support).

Registering your purchase and equipment with us helps us process your repair claims quicker and more efficiently.

Thank you for your cooperation!

2. CONTROL ELEMENTS

2.1 The front

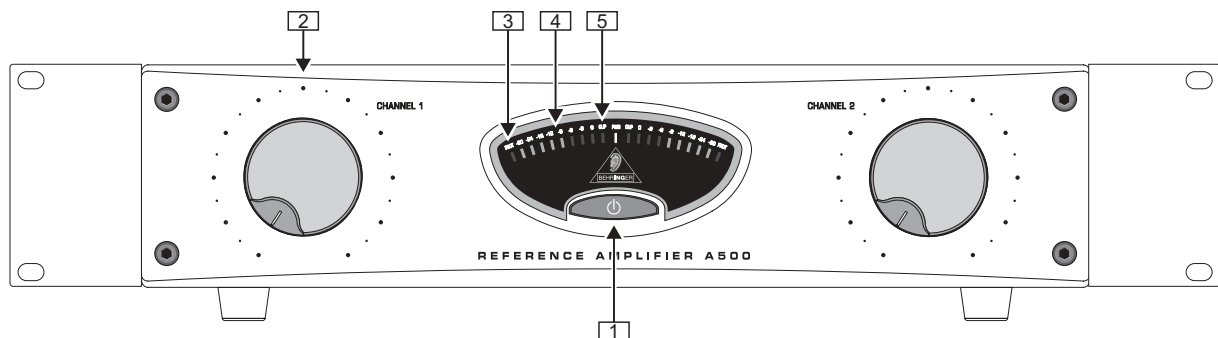

Fig. 2.1: Control elements in the front

- 1 The **POWER** switch is used to power up the A500. The **POWER** switch should always be in its "Off" position when you connect the unit to the mains.
POWER LED lights up as soon as you power up the A500.

- 👉 Please note: Merely switching the unit off does not mean that it is fully disconnected from the mains. When not using the unit for prolonged periods of time, please unplug the unit's power cord from the power outlet.

REFERENCE AMPLIFIER A500

- ☞ Your power amp should always be the last device you power up, since some equipment in the signal path creates strong impulses which are then amplified in the amp and are passed onto the loudspeakers, possibly damaging them. Consequently, always let your power amp be the first device you power down.
- 2 Each channel features a volume control. Use it to adjust gain on your A500. Both volume controls should be turned all the way to the left whenever you power the unit up or down. If an active signal is present on the input, turning the volume down will protect your speakers and your ears from unwanted “pops” or transients.
- 3 The *PROT* LED lights up whenever the protective circuitry mutes the speaker output. Please turn your A500 off immediately whenever this LED is lit.

- ☞ The protective circuitry is activated if the amp gets too hot. Let your A500 cool down a little before you turn it on again. Besides, check if the heat sink has enough space around it to perform its job.
- 4 The high-precision power indicator gives out current signal strength.
- 5 The *CLIP* LED lights up when the signal is distorted. Should distortion occur, reduce the input level, so that the CLIP LED no longer lights up.
- ☞ If the *CLIP* LED remains being lit, check the cable connection to the speakers because there might be a short on the speaker output.

2.2 The back

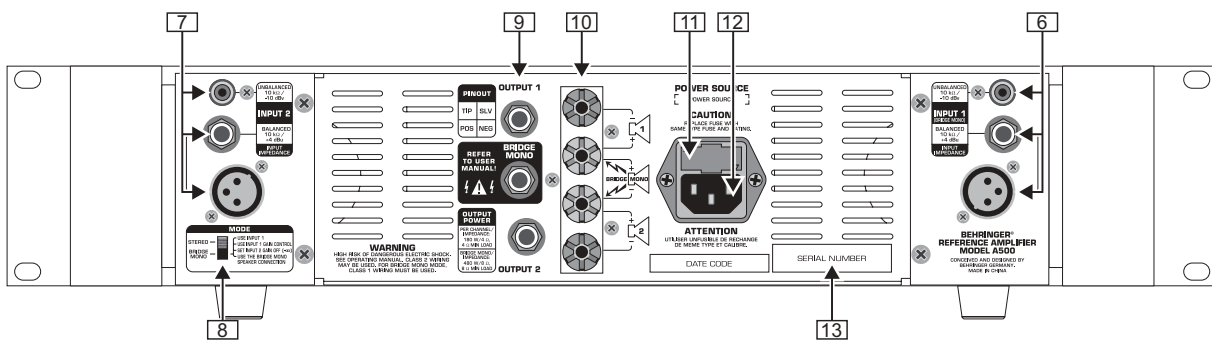

Fig. 2.2: Control elements and connections in the back

- 6 **CHANNEL INPUT 1 (MONO).** Connect the signal source whose output needs to be amplified.
- ☞ Please use only one of the three input connectors per channel at any one time!
Here you will connect an output of your mixing console, your HiFi preamp or another signal source.
Our rack mixing console EURORACK PRO RX1602, with its eight mono-usable balanced stereo channels, is an ideal choice for signal processing and source selection.
The connections for both channels are laid out as RCA, XLR and 1/4" TRS stereo connectors. The cinch inputs are intended for use with outputs laid out as unbalanced signals with a -10 dBV line signal level. Because these inputs are more sensitive than others, you can directly connect a CD player or a DAT recorder. Of course this input can also be used for connecting mixing consoles and similar equipment.
The XLR and 1/4" TRS stereo connectors are laid out balanced, but they too can of course be used to connect unbalanced signals. Their sensitivity is +4 dBu (also see ch. 4).
Generally speaking, you should choose balanced over unbalanced signals in order to guarantee the highest noise protection.
Due to safety considerations, the inputs can not be used in parallel. However, if you are using cinch and XLR or 1/4" TRS connectors simultaneously, the cinch input is given preference, and the other signal is muted.
- ☞ If you wish to use the A500 in mono-bridged mode, please only use one of the channel 1 inputs!
- 7 **CHANNEL INPUT 2.** These are the inputs for channel 2.

- 8 The **STEREO/BRIDGED MONO** switch is used to toggle between the two operating modes of your A500.
- ☞ Please power the A500 down using the **POWER** switch each time you change the operating mode. Similarly, only connect/disconnect speaker connectors if the A500 has first been powered off!
- 9 **OUTPUT 1, OUTPUT 2** and **BRIDGED MONO**: These are the speaker connectors of your A500 laid out as 1/4" TS mono connectors. When in mono-bridged mode, only use the **BRIDGED MONO** output.
- ☞ Keep in mind the minimum power impedance of **4 Ohms per channel in stereo mode**. When in mono-bridged mode, a loudspeaker whose impedance is at least **8 Ohms** must be used.
- 10 In addition to XLR or 1/4" TRS connectors, you can also use binding posts for connecting speaker cables. When in mono-bridged mode, make sure to connect your cables to both middle connectors—as shown on the unit itself.
- 11 **FUSE SWITCH/VOLTAGE SELECTION.** Before connecting the unit to the mains, please check if the voltage selector corresponds to your local voltage. When replacing fuses, you should only use fuses of the same type and rating. With some units, the fuse switch can be put into two different positions in order to select between 230 V and 120 V operation. Please bear in mind: If you wish to use your equipment outside of Europe running on 120 V, you will have to use a fuse with a higher Ampere value.
- 12 The mains connection is made via a standard **IEC RECEPTACLE**. A matching cable is enclosed.
- 13 **SERIAL NUMBER.**

REFERENCE AMPLIFIER A500

3. APPLICATION EXAMPLES

3.1 Stereo mode

In this mode, both channels run independently with a separate input signal. Connect passive loudspeakers, preferably high-quality studio monitors, such as the BEHRINGER TRUTH B2031P. Set the STEREO/BRIDGED MONO switch [8] to "STEREO" to enable stereo mode.

⚠ Please use the POWER switch to power down your A500 before making any changes to the operating mode settings.

⚠ Keep in mind the minimum load impedance of 4 Ohms per channel in stereo mode.

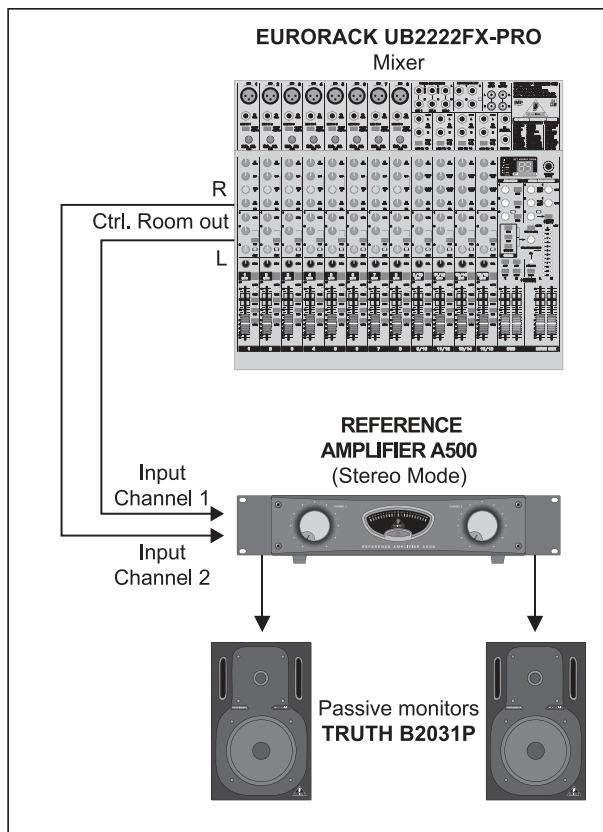

Fig. 3.1: A500 in stereo operation

Additional examples:

- ▲ Two independent mono signals, e.g. instrument signal and monitor mix
- ▲ Bi-amp operation, with the bass signal on channel 1 and the treble signal on channel 2

3.2 Mono-bridged mode

In this mode, the voltages of both channels are added up and routed to just one loudspeaker. This results in a doubling of voltage, quadrupling of the peak power value and roughly tripling of the continuous power output on a single channel. The input and the gain control on channel 1 are used in mono-bridged mode. The channel 2 control elements are not used. **ATTENTION: To avoid cancellations due to internal phase inversion, the GAIN control on channel 2 must be turned all the way to the left!**

Use this operating mode to feed the output of both channels into a single 4-Ohm load. Set the STEREO/BRIDGED MONO switch [8] to "BRIDGED MONO."

Please only connect the speaker using the BRIDGED MONO connector [9] or by using both of the middle binding posts [10].

⚠ Always power the A500 down using the POWER switch whenever you make any changes to the operating mode settings.

⚠ Keep in mind the minimum load impedance of 8 Ohms in mono-bridged mode.

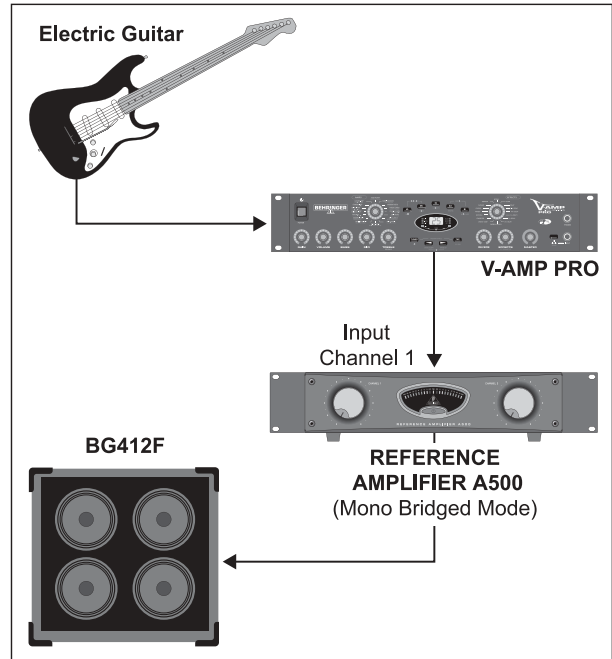

Fig. 3.2: Mono-bridged operation

⚠ If your amp is overdriving for a longer period of time, it may become muted for several seconds at a time. Always select appropriate volume values to avoid overdriving.

Safety precautions for mono-bridged operation

A voltage of up to 60V RMS is present between the output connectors of the A500. Always adhere to all appropriate safety precautions when connecting your speakers to avoid the risk of electric shock.

Running your amp in mono-bridged mode puts both the amp and your loudspeakers under additional strain. Excessive overdriving can result in premature shutting down of the unit itself or permanent damage to the speakers. Make sure that your speaker (impedance at least 8 Ohms) and the cables you use can indeed handle the power load fed into/through them.

4. INSTALLATION

4.1 Installation in a rack

Your A500 can be installed into a 19" rack and requires two rack spaces. Please use four attaching screws and washers for installation. Reinforce the back end, especially for on-the-road use. Please ensure that enough cool air reaches the rack, especially if other rack equipment generates a lot of heat. Due to its weight, we recommend installing the A500 in the lower portion of your rack. If you are installing several amps in a single rack, you should leave some space between individual amps (approx. 1 height unit) to allow for sufficient cooling.

REFERENCE AMPLIFIER A500

☞ The A500 has massive heat sinks on its side frame that guarantee reliable operation. Never block air supply to these heat sinks because excessive heat may damage the components inside your amp. Even though the protective circuitry guards the inside components from damage caused by excessive internal temperatures, you should still double-check where the amp is placed and inspect cable connections if you are experiencing thermal protection dropouts.

4.2 Connections

Inputs

If you wish to use XLR connections for unbalanced input signals, connect the unused pin on the XLR connector (pin 3) with the ground. No modification is needed if using mono jacks (also see ch. 4.3).

☞ Should you register distracting signals such as noise or hissing, we recommend separating the amp input from the signal source. This way, you can quickly determine if the noise originates in the equipment connected to the amp. Always make sure to completely lower amplification of both channels before powering up the amp (GAIN control turned all the way to the left). Otherwise, permanent damage to your speakers may occur.

Outputs

Your A500 offers several output connection possibilities: two 1/4" TS mono connectors and two pairs of touch-safe binding posts. In addition to both 1/4" TS mono connectors for individual channels, the A500 also features an extra 1/4" connector for use in mono-bridged mode.

☞ Whenever possible, use thick and short speaker cables to minimize power losses. Never route output cables near input cables.

When using binding posts, make sure that the wire insulation is not stripped more than what is necessary, and that wires are completely inserted into the binding post so that no bare wire is visible. Cable clamps must be isolated to avoid the possibility of electric shock. When running the amp in mono-bridged mode, always use the middle two binding post connectors, paying attention to correct polarity.

☞ **ATTENTION!** If you notice bare cable endings on the binding post connectors, disconnect the AC mains and remedy the improper output connection before powering the amplifier on again.

Connecting to the mains

Always connect your power amplifier to the voltage specified on the rear of the unit. Connecting the amp to incorrect voltage can permanently damage it (also see ch. 2, under **11** FUSE SWITCH/VOLTAGE SELECTION).

Before powering up the amplifier, double-check all connections and fully lower the gain settings.

4.3 Audio connections

Various cables are needed for different types of applications. The following illustrations show the correct wiring. Always use high-grade cables.

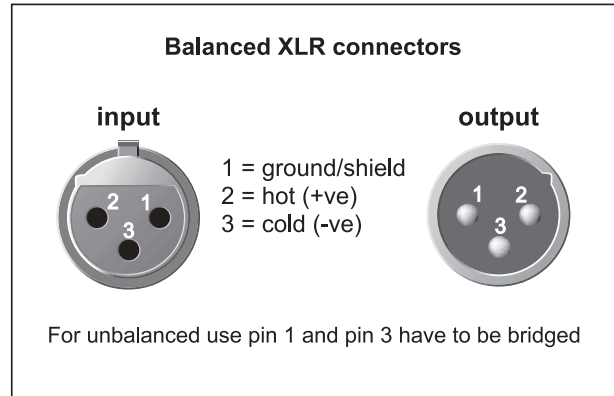

Fig. 4.1: XLR connections

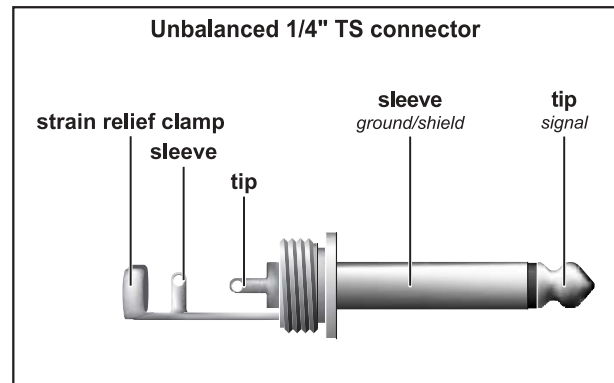

Fig. 4.2: 1/4" TS connector

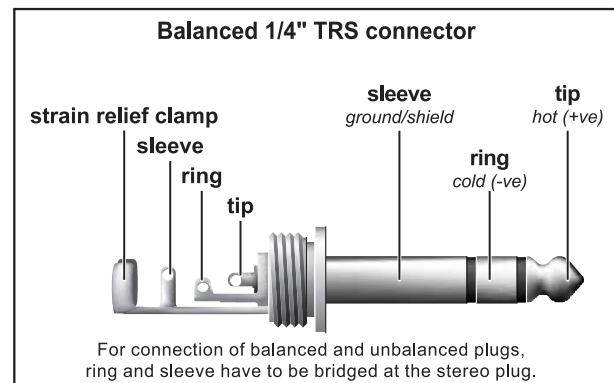

Fig. 4.3: 1/4" TRS connector

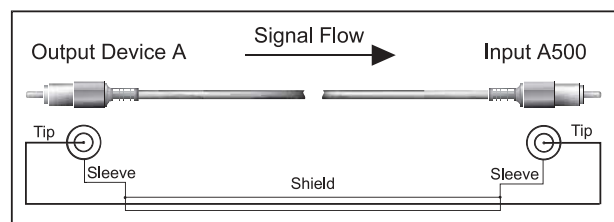

Fig. 4.4: Unbalanced connection using a cinch cable

REFERENCE AMPLIFIER A500

5. SPECIFICATIONS

OUTPUT POWER

Both channels running:
4 Ω per channel 230 W
8 Ω per channel 160 W

Mono-bridged operation:
8 Ω 500 W

DISTORTION < 0.01%

FREQUENCY RANGE 10 Hz - 25 kHz, +0/-1 dB

CROSSTALK typically 85 dB @ 1 kHz

NOISE -100 dB, 20 Hz - 20 kHz, unweighted

AMPLIFICATION 25x (28 dB)

CONTROLS Gain controls (channels 1 and 2)

SWITCHES POWER switch;
STEREO/BRIDGED
MONO switch

INDICATORS

Rejection display -30 to 0 dB, clip

Protective circuitry PROT LED, yellow

AUDIO INPUTS

Type Balanced XLR and
1/4" TRS stereo connectors,
cinch connectors

Impedance 10 k Ω (unbalanced),
10 k Ω (balanced)

INPUT SENSITIVITY

V RMS (@ 4 Ω) XLR and 1/4" TRS stereo
connectors:
1.3 V (+4.5 dBu)
Cinch connectors:
320 mV (-10 dBV)

AUDIO OUTPUTS

Type 1/4" TS mono connectors
and "touch-proof" binding posts

COOLING Convection-type cooling

PROTECTIVE CIRCUITRY against: short circuit and
thermal overload

OUTPUT CIRCUIT TYPE Push-pull Class AB

POWER SUPPLY

Voltage USA/Canada
120 V~, 60 Hz
China 220 V~, 50 Hz
Europe/U.K./Australia
230 V~, 50 Hz
Japan 100 V~, 50 - 60 Hz
general export model
120 V/230 V~, 50 - 60 Hz

Power consumption max. 3.6 A 230 V / 6.5 A 120 V

Breaker 100 - 120 V~: T 10 A H 250 V
200 - 240 V~: T 5 A H 250 V

Mains connector Standard IEC receptacle

DIMENSIONS/WEIGHT

Dimensions (H x W x D) approx. 19" (482.6 mm) x 10.85"
(257.5 mm) x 4" (101.6 mm)

Weight approx. 18.5 lbs (8.4 kg)

BEHRINGER is constantly striving to maintain the highest professional standards. As a result of these efforts, modifications may be made from time to time to existing products without prior notice. Specifications and appearance may differ from those listed or illustrated.

REFERENCE AMPLIFIER A500

6. WARRANTY

§ 1 OTHER WARRANTY RIGHTS AND NATIONAL LAW

1. This warranty does not exclude or limit the buyer's statutory rights provided by national law, in particular, any such rights against the seller that arise from a legally effective purchase contract.

2. The warranty regulations mentioned herein are applicable unless they constitute an infringement of national warranty law.

§ 2 ONLINE REGISTRATION

Please do remember to register your new BEHRINGER equipment right after your purchase by visiting www.behringer.com (alternatively www.behringer.de) and kindly read the terms and conditions of our warranty carefully. Registering your purchase and equipment with us helps us process your repair claims quicker and more efficiently. Thank you for your cooperation!

§ 3 WARRANTY

1. BEHRINGER (BEHRINGER International GmbH including all BEHRINGER subsidiaries listed on the enclosed page, except BEHRINGER Japan) warrants the mechanical and electronic components of this product to be free of defects in material and workmanship for a period of one (1) year* from the original date of purchase, in accordance with the warranty regulations described below. If the product shows any defects within the specified warranty period that are not excluded from this warranty as described under § 5, BEHRINGER shall, at its discretion, either replace or repair the product using suitable new or reconditioned parts. In the case that other parts are used which constitute an improvement, BEHRINGER may, at its discretion, charge the customer for the additional cost of these parts.

2. If the warranty claim proves to be justified, the product will be returned to the user freight prepaid.

3. Warranty claims other than those indicated above are expressly excluded.

§ 4 RETURN AUTHORIZATION NUMBER

1. To obtain warranty service, the buyer (or his authorized dealer) must call BEHRINGER (see enclosed list) during normal business hours **BEFORE** returning the product. All inquiries must be accompanied by a description of the problem. BEHRINGER will then issue a return authorization number.

2. Subsequently, the product must be returned in its original shipping carton, together with the return authorization number to the address indicated by BEHRINGER.

3. Shipments without freight prepaid will not be accepted.

§ 5 WARRANTY REGULATIONS

1. Warranty services will be furnished only if the product is accompanied by a copy of the original retail dealer's invoice. Any product deemed eligible for repair or replacement under the terms of this warranty will be repaired or replaced.

2. If the product needs to be modified or adapted in order to comply with applicable technical or safety standards on a national or local level, in any country which is not the country for which the product was originally developed and manufactured, this modification/adaptation shall not be considered a defect in materials or workmanship. The warranty does not cover any such modification/adaptation, irrespective of whether it was carried out properly or not. Under the terms of this warranty, BEHRINGER shall not be held responsible for any cost resulting from such a modification/adaptation.

3. Free inspections and maintenance/repair work are expressly excluded from this warranty, in particular, if caused by improper handling of the product by the user. This also applies to defects caused by normal wear and tear, in particular, of faders, crossfaders, potentiometers, keys/buttons, tubes, guitar strings, illuminants and similar parts.

4. Damages/defects caused by the following conditions are not covered by this warranty:

▲ improper handling, neglect or failure to operate the unit in compliance with the instructions given in BEHRINGER user or service manuals.

▲ connection or operation of the unit in any way that does not comply with the technical or safety regulations applicable in the country where the product is used.

▲ damages/defects caused by force majeure or any other condition that is beyond the control of BEHRINGER.

5. Any repair or opening of the unit carried out by unauthorized personnel (user included) will void the warranty.

6. If an inspection of the product by BEHRINGER shows that the defect in question is not covered by the warranty, the inspection costs are payable by the customer.

7. Products which do not meet the terms of this warranty will be repaired exclusively at the buyer's expense. BEHRINGER will inform the buyer of any such circumstance. If the buyer fails to submit a written repair order within 6 weeks after notification, BEHRINGER will return the unit C.O.D. with a separate invoice for freight and packing. Such costs will also be invoiced separately when the buyer has sent in a written repair order.

§ 6 WARRANTY TRANSFERABILITY

This warranty is extended exclusively to the original buyer (customer of retail dealer) and is not transferable to anyone who may subsequently purchase this product. No other person (retail dealer, etc.) shall be entitled to give any warranty promise on behalf of BEHRINGER.

§ 7 CLAIM FOR DAMAGES

Failure of BEHRINGER to provide proper warranty service shall not entitle the buyer to claim (consequential) damages. In no event shall the liability of BEHRINGER exceed the invoiced value of the product.

* Customers in the European Union please contact BEHRINGER Germany Support for further details.

Technical specifications and appearance subject to change without notice. The information contained herein is correct at the time of printing. The names of companies, institutions or publications pictured or mentioned and their respective logos are registered trademarks of their respective owners. Their use neither constitutes a claim of the trademarks by BEHRINGER® nor affiliation of the trademark owners with BEHRINGER®. BEHRINGER® accepts no liability for any loss which may be suffered by any person who relies either wholly or in part upon any description, photograph or statement contained herein. Colours and specification may vary slightly from product. Products are sold through our authorised dealers only. Distributors and dealers are not agents of BEHRINGER® and have absolutely no authority to bind BEHRINGER® by any express or implied undertaking or representation. No part of this manual may be reproduced or transmitted in any form or by any means, electronic or mechanical, including photocopying and recording of any kind, for any purpose, without the express written permission of BEHRINGER Spezielle Studioteknik GmbH. BEHRINGER® is a registered trademark.

ALL RIGHTS RESERVED. © 2005 BEHRINGER International GmbH,
Hanns-Martin-Schleyer-Str. 36-38, 47877 Willich-Münchheide II, Germany.
Tel. +49 2154 9206 0, Fax +49 2154 9206 4903