

QLS2800s signal generator

First, Overview

The qls2800s series of instruments use large-scale fpga integrated circuits and 32-bit high-speed arm microprocessors. The internal circuit adopts a surface mount process, which greatly improves the anti-interference and service life of the instrument. The display interface adopts a 2.4-inch tft LCD screen with 320*240 high resolution, which can display all the parameters of the channel and prompt the current button functions, effectively utilize the button resources, avoiding frequent user button operations, greatly enhanced Operability. The instrument has great advantages in signal generation, waveform scanning, parameter measurement and use. It is an ideal test and measurement equipment for electronic engineers, electronic laboratories, production lines and teaching and research.

Second, the model

This series of instruments is divided into two models, the main difference is the maximum frequency of the output sine wave, as follows:

QLS2806S sinusoidal signal frequency up to 5MHz, amplitude up to 10V_{p-p};

Third, the instrument characteristics

- 1, using direct digital synthesis (dds) technology, fpga design, ultra-low power consumption;
- 2, a single dc5v power adapter power supply, easy to carry;
- 3, using 2.4 inch tft true color LCD screen, with variable function buttons and rotary encoder, greatly enhanced the ease of use of the

machine;

4. Basic function waveforms such as sine wave, triangle wave, square wave, sawtooth wave, and pulse wave with adjustable duty cycle;

5, the output signal frequency can be as small as 0.01 Hz;

6. There are 10 sets of parameter storage bits of $m_0 \sim m_9$, and the data of m_0 is automatically called up when booting;

7, the waveform frequency resolution is at least 0.01Hz, and the amplitude resolution is at least 10mV;

8, with manual trigger, external trigger two trigger mode, can make the machine output $1 \sim 999999$ arbitrary pulse

Rushing

9, the pulse wave duty cycle adjustment is accurate to 0.5%;

11. Frequency scanning with an end point;

12, with frequency measurement, counting function;

13. All parameters can be calibrated by internal procedures;

14, powerful communication functions, completely open communication protocol, making secondary development very simple;

15, after connecting with the PC, can use the pc to control the instrument

Fourth, technical indicators

project		parameter	
Main characteristics	Frequency Range	Sine wave	QLS2802S: 0Hz~2MHz; QLS2805S: 0Hz~5MHz;
		Square wave	0Hz~2MHz
		Triangle wave	0Hz~2MHz
		Sawtooth wave	0Hz~2MHz
	Output modulation	Frequency scanning, bursting	
	Waveform type	Sine wave, square wave, triangle wave, sawtooth wave	
	Frequency error	$\pm 8 \times 10^{-6}$	
	Frequency stability	$\pm 5 \times 10^{-6}$	
	Amplitude range (peak-to-peak)	10mV _{p-p} ~10V _{p-p} ;	
	Output impedance	50Ω ± 10%	
	Amplitude resolution	10mV _{p-p}	
	Amplitude stability	±0.5% (every 5 hours)	
Amplitude error	± 1% + 10mV (frequency 1KHz, 8 V _{p-p})		

	Offset range	-100%~+100%
Sine wave	Harmonic resistance system	40dBc(<1MHz) ,35dBc(1MHz~5MHz)
	Distortion	<0.8%(20Hz~20KHz)
Square wave	Lifting time	≤28ns
	Overshoot	≤10%

	Duty cycle adjustment range	0.1%~99.9%
TTL/CMOS	Lifting time	≤28ns
	Low level	<0.3V
	High level	1V~5V
Sawtooth wave	Duty cycle >50.1%	Rising sawtooth
	Duty cycle <49.9%	Sawtooth wave
scan ning	Scan mode	Sweep
	Scan time	0.1S~999.9S
	Scanning range	0-Max.Freq
External measurement function	Frequency measurement range	0.01Hz~60MHz
	Minimum input voltage	0.5Vp-p
	Maximum allowable input voltage	10Vp-p
	Counting range	0~4294967295
	Counting method	Manual
	Source selection	Ext. IN input (analog signal)
storage	Quantity	10
	position	M0 to m9
inter face	Interface mode	Use usb to serial interface
	Communication rate	57600 bps
	Protocol	Using the command line, the agreement is open
power supply	DC	5V
size	Length × width × height	170×200×70mm
weight	Stand-alone	518g

Five, panel description

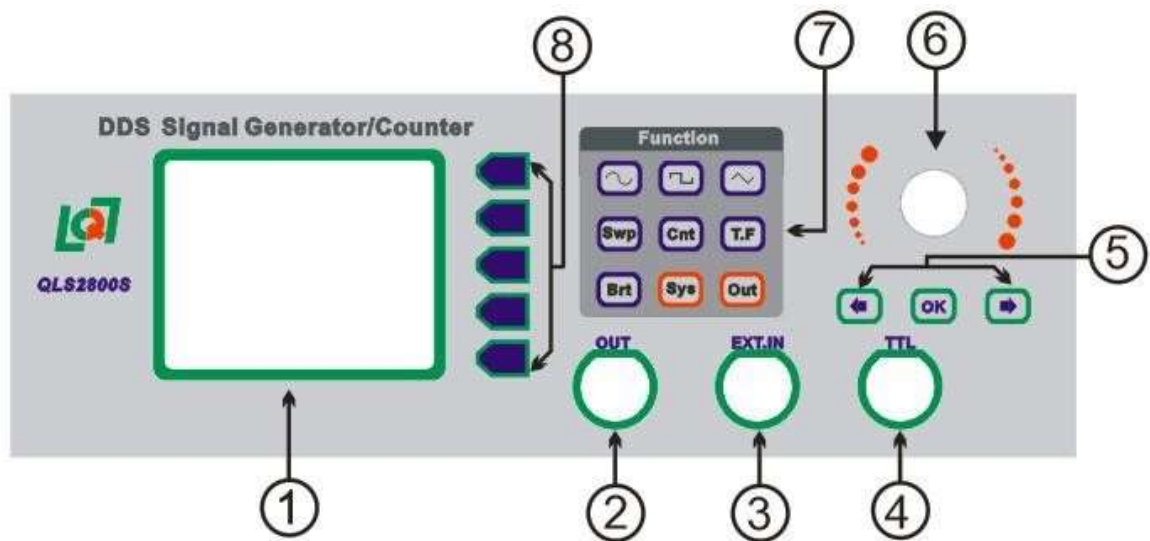

1	Data display area	5	Operation button
2	Waveform output port	6	Code knob
3	External signal input port	7	function button
4	Ttl signal output port (synchronous out)	8	Auxiliary operation button

Six, display instructions

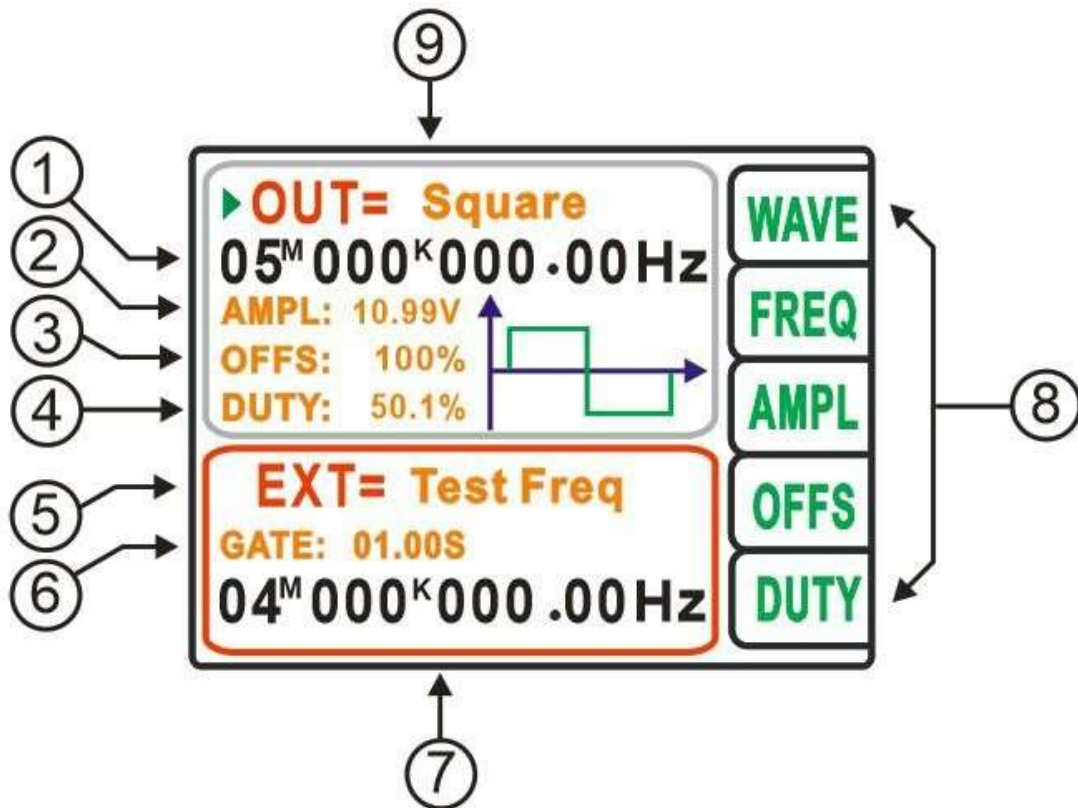

1	Output frequency display	6	Gate time
2	Amplitude	7	Measuring frequency
3	Bias	8	Function option
4	Duty cycle	9	Output waveform
5	Measurement function	10	air

Six, operating instructions

1, set the waveform

In the main interface, click the **WAVE** / **波形** button, then rotate the adjustment knob to change the output waveform.

Click on the main interface  **FREQ** / **频率** Button, click The button changes the frequency adjustment step value, and then the adjustment knob increases or decreases the output waveform frequency value.

3, the amplitude setting

Click the **AMPL** / **幅度** button in the main  interface, click the button Change the amplitude adjustment step value, then adjust the knob to increase or decrease the amplitude value of the output waveform.

4, offset adjustment



Click the **OFFS** / **偏置** button in the main  interface, click The button changes the offset adjustment step and the adjustment knob increases or decreases the output waveform offset.

5, duty cycle adjustment

Click the **DUTY** / **占空** button in the main  interface, click The button changes the duty cycle adjustment step value, and then the adjustment knob increases or decreases the duty cycle of the output square wave.

6, pulse counting function

Click the “Cnt” button, the cursor jumps to the frequency measurement function display page, and the main page displays the function option on the right side to switch to the status shown in

Figure 6-1 below. Connect the signal to be tested to the Ext.In interface, and then click the button to start the frequency measurement .) function, click the  button to pause the frequency measurement function, and click the  button to clear the frequency measurement value.

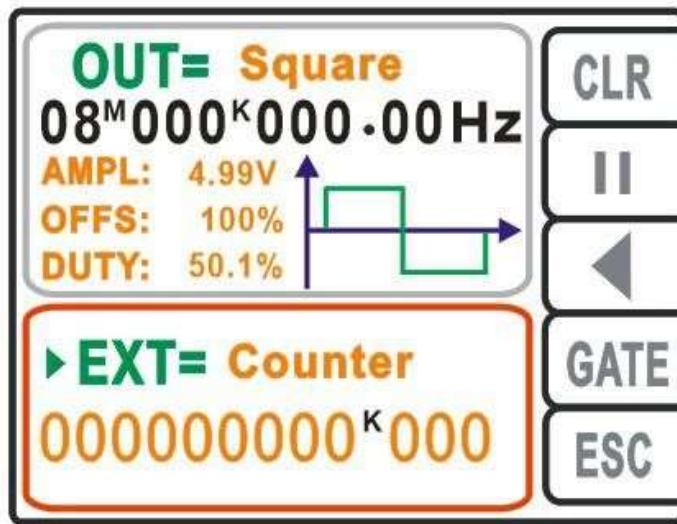

Figure 6-1

7, frequency measurement function

Click the “tf” button, the cursor jumps to the frequency measurement function display page, and the main page displays the right function option.

Switch to the following Figure 7-1 status, click **GATE** / **闸门** button to enter the frequency gate time setting function, then rotate the knob to adjust the frequency gate time, a total of 4 gate time 0.01S, 0.1S, 1.0S, 10.0S, The longer the gate time, the higher the measurement frequency resolution. After setting the gate time, connect the signal to be tested to the Ext.In interface, then click the **◀** button to start the frequency measurement function. Click the **||** button to pause the frequency measurement function. Click the **CLR** button to clear the frequency measurement value. . . .

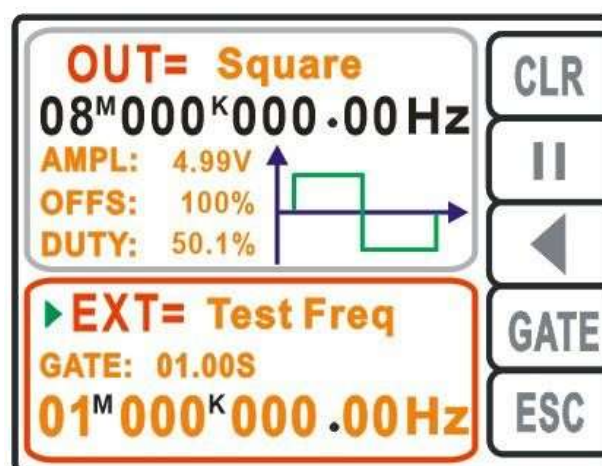



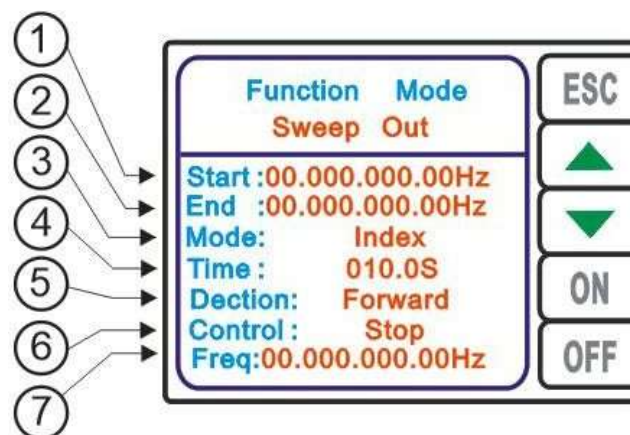

Figure 7-1

8, sweep function

Click the “Swp” function, enter the sweep setting interface, click the   button to switch the adjustment parameters, and click the   button to change the adjustment parameter step value. Turn the knob to increase or decrease the parameter value.



- (1) The starting value (Start) is the initial frequency of the sweep frequency;
- (2) End value (End) sweep end frequency value;
- (3) Mode sweep mode, there are two sweep modes: linear (Index) scan and logarithmic (Linear) scan;
- (4) Time (Time) sweep time setting;
- (5) Directions (Dection) sweep direction, there are three scanning directions, namely Forward scan, Reverse scan, Reciprocat scan;
- (6) The sweep control (Control) shows the start and stop status of the sweep.
- (7) The frequency (Freq) is displayed as the frequency sweep real-time frequency;
- (8) Click the “esc” button to scan the control page and return to the main page.



1	Sweep start value	5	Sweep waveform
2	Sweep stop value	6	Sweep running status
3	Sweep mode	7	Scan real-time frequency
4	Sweep time	8	air

9, burst function

Click the “Brt” button to enter the function page, and click the FUNC button to enter the burst settings page as shown in Figure 9-1.

⌘ Trigger the number of pulses (Number), click the “PULS” button to enter the burst number setting function, then click  \  on the panel to change the step value of the parameter adjustment, and adjust the knob to change the size of the setting parameters.

⌘ Trigger mode (Mode), (Manual) manual trigger, after setting the parameters and starting the trigger function, click OK to enable the trigger function. (External) External trigger. After the parameter is set and the trigger function is activated, the burst function is enabled by an external signal.

⌘ Control function (Control), click the “ON” button to open the burst function, click “OFF” off



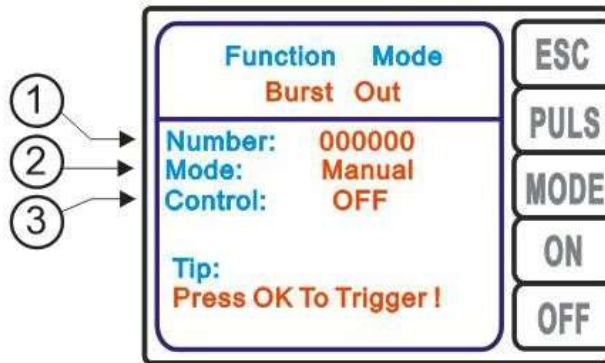

Closed burst function.

⌘ Click the “esc” button to exit the burst control settings page and return to the main page.



10, system settings

Click the “Sys” button to enter the system parameter setting page as shown in Figure 10-1.

(1) Parameter save and recall (Save&Recall), the instrument has 10 sets of data storage locations, power-on default output 0 position data, click  \  button to switch address bit parameters, click  \  variable adjustment parameter step value. Turn the knob to increase or decrease the address. Then click “save” to save the data or click “real” to call up the data for the corresponding location.

(2) Sound: When the adjustment is ON, the beep is turned on; when it is “OFF”, the beep is turned off, and “SAVE” is clicked to save the setting state.

(3) Language: When the option is displayed as “English”, the operation interface is English. When the display is “Chinese”, the operation interface is Chinese. Click “SAVE” to save the setting status.

(4) Click the “esc” button to exit the parameter settings page and return to the main page.



1	Parameter save callout address bit	3	Language features
2	Beep sound enable	4	Frequenc y calibrat ion

Seven, contact information

Address: A110, Building 1, Entrepreneurship Center,

96 Ruida Road, Gaoxin District, Zhengzhou City. Tel:

0371-56723980

mailbox: 2217881244@qq.com

QQ: 2217881244