

BG7TBL LCD-GPS DISCIPLINED OSCILLATOR

Instruction Manual

Version 1.1 - D

This User's Manual describes how to Install and Use the GPS Disciplined Clock

For Assistance Contact:

WUTONG electronic

Longhua, Shenzhen, Guangdong, China

Website (Chinese): <http://bg7tbl.taobao.com>

TEL/VX: 0086-134 2795 9750

Email: bg7tbl@qq.com , 6N2 [<mailto:bg7tbl@qq.com>] , bg7tbl@126.com

Table of Contents

Section 1: Key Features	4
Section 2: Overview.....	4
Section 3: Technical Parameters	4
Section 4: Equipment Installation	5
4.1 Rear Panel	5
4.2 Front Panel	6
4.3 Computer Connection	6
4.4 Rear Panel Status LED's.....	7
4.5 Front Panel LCD Status	7
4.6 Display Commands	8
4.7 Notes	9
Section 5: Block Diagram	9
Section 6: FAQ	10
Section 7: Programming Notes	11

Section 1: Key Features

1. 10 MHz low noise sine wave, high stability output.
2. 1 PPS (Pulse Per Second) UTC synchronized output.
3. High sensitivity GPS receiver that can achieve Lock without direct line of sight, although for high accuracy, a full view of the sky is required.
4. ALM: Red LED Warning; the OCXO has not yet reached its initial set temperature.
5. Power Requirements 12 VDC / 1.5 A, with universal AC Power Adapter.
6. Inexpensive, compact, and user programmable options for the LCD display format.
7. Unique algorithm to maintain high accuracy 10 MHz Frequency Standard output.
8. LCD Display monitors GPS Lock, Signal Strength, and 10 MHz frequency error.

Section 2: Overview

The GPSDO (GPS Disciplined Oscillator) uses GPS signals to control the 10 MHz OCXO (Oven Controlled Crystal Oscillator), and to provide a accurate GPS controlled 1 PPS (Pulse Per Second) output. A unique software algorithm filters and processes the GPS timing signal to improve the overall timing and frequency accuracy. The front panel LCD display provides GPS Signal Strength, Time, and Error Calculation for the 10 MHz output frequency.

Section 3: Technical Parameters

NAME: LCD-GPS Disciplined 10 MHz Frequency Standard.

POWER: Nominal 12 VDC (11.7-12.9), ≤ 15 W.

GPS ANTENNA POWER: 3.3 VDC (default), or optional 5 VDC (50 mA each).

1 PPS OUTPUT: Square Wave, 3.3 Vpp.

10 MHz OUTPUT: Sine Wave 1 Vrms, 10-15 dBm.

10 MHz ACCURACY: Allow a 30 minute warm up time. Initially it will be within 0.05 Hz at 10 MHz, and better than 0.005 Hz within 5 hours. And will achieve $\sim 0.000,25$ Hz ($\leq 2.5 \times 10^{-11}$), or up to 2 orders magnitude higher than the OCXO's capability.

RS232 OUTPUT: GPS NMEA Data.

SIZE: H 55mm (2.2") x W 107mm (4.2") x D 172mm (6.8") including protrusions.

PROVIDED ACCESSORIES: 1. Power Adapter, 110-220 VAC to +12 VDC, with 5.5/2.1 mm male, supplies DC power to LCD-GPSDO. 2. GPS Antenna with 5 m of coax, SMA male..

Section 4: Equipment Installation

4.1 Rear Panel



Rear Panel

1. Status LEDs

ALM: Red LED indicates OCXO is warming, and not at initial set temperature.
GPS LOCK: Green LED 'ON' indicating GPS is tracking and locked. RUN:
Flashing green LED (~1 PPS) indicates normal operation state.

2. RS232 (DB9) connector provides RS232 NMEA GPS data.

3. GPS locked 1 PPS Square Wave output, with timing valid on the rising edge.

4. 10 MHz Frequency Standard, Sine Wave output.

5. SMA connector for Active GPS antenna, with DC power for it.

6. External DC power, 5.5/2.1mm, center positive, 11.7 - 12.9 VDC, < 15 W.

power connection (as is provided on the supplied AC Power Adapter).

4.2 Front Panel



Front Panel

LCD display provides Signal Strength, Time, GPS Lock, and 10 MHz Error status.

4.3 Computer Connection (use is optional)

GPSDO-DB9	PC-DB9
PIN2	PIN2
PIN3	PIN3
PIN5	PIN5
PIN8	PIN8

REQUIRED COMPUTR DATA CONFIGURATION:

Baud Rate 9600bps, Data bits 8, Stop bit 1, Parity bit NONE, Flow control NONE

4.4 Rear Panel Status LEDs

- Power up: All three LEDs will light momentarily followed by 'RUN' (flashing), 'ALM' ON, and 'GPS Lock' OFF.
- Power up current: Less than 1.5 A.
- Preheat: The OCXO requires 30 minutes to warm up and stabilize. When it initially reaches operating temperature, the 'ALM' (red) will turn OFF. When the GPS is Locked, the 'GPS Lock' (green) will turn ON indicating normal operation is in process.
- Normal: 'RUN' (green) flashing, 'GPS Lock' (green) ON. 'ALM' (red) OFF, means that the GSDO is operating normally.

4.5 Front Panel LCD Display Status Indications

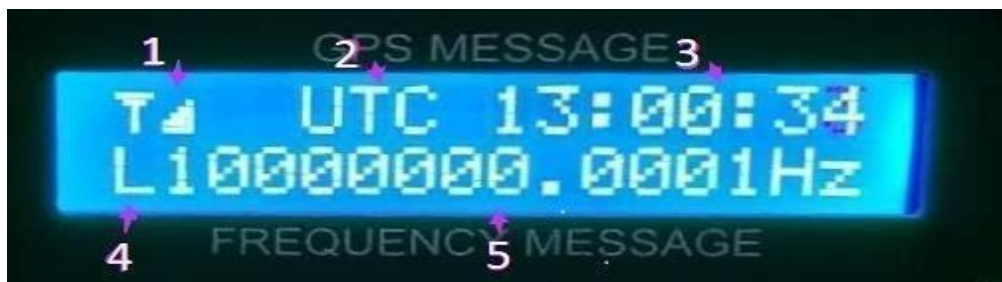

A type 1602 LCD is used with a display area of 2 lines and 16 characters each.

Description of the LCD display format:

1. GPS signal strength, 1 to 5 bars, 1 bar being Weak, and 5 bars Strong.
2. User defined 6-character display area.
3. Time Display; user options are available for international Time Zones.
4. GPS Disciplined state display, 'L' is indicated for a GPS Lock condition. Highest Accuracy is when the least significant digits are 0.
5. Reference output frequency/accuracy display area (user options available).

At power up, LCD display will momentarily illuminated fully, and briefly display:

GPSDO UTC +/- XX:XX (configured UTC offset), and
BG7TBL V20171210 (Designer, and Version number)

GPS NO FIX - is displayed on the LCD until a GPS Lock is achieved.

4.6 Display Commands - User Display Options

- An Internal 'Run/Test Mode Jumper' must set to the Test Mode for programming.
Test Mode is enabled by placing a connection across this Jumper (on main PCB behind the 3 LEDs)
- Configure a PC for Terminal emulation with an appropriate software utility* (see Section 7, Programming Notes.
- **User LCD Display Programming basic command string (\$) structure follows:**
The instructions are in 'ASCII code' starting with: \$GPGTC', then 12 bits (X1-X12), and ending with 'T*'
\$GPGTC, X1 X2 X3 X4 X5 X6 X7 X8 X9 X10 X11 X12 T*
X1, sets frequency display mode:
 - '0' for "10000000.0000 Hz" format
 - '1' for "10M +/- 0.0000 Hz" format
 - '2' for "10M +/- 000.00 ppb" format (i.e. 001.00 = 1×10^{-9} , 000.01 = 1×10^{-11})
 - '3' for "10M +/- 0.00000 ppm" format (i.e. 1.00000 = 1×10^{-6})X2 - X7, sets the user defined 6-character area
X8, sets positive time offset from UTC '+' (default is +, e.g. +0000)
X9 & X10, two digit hour offset, '00' to '23' (default 00, for UTC Time)
X11 & X12, two-digit minute offset, '00' to '59' (default is 00, seldom ever changed)
- **Note: The following command strings use 1 Space before 'UTC' and 2 Spaces after.**
- Example 1: PPM frequency format display mode, w/UTC displayed as 'BJT' (Beijing) Time, with a time offset of 8:00 hours, the command would be;
\$GPGTC,3 BJT +0800T*
- Example 2: 10000000.0000 Hz frequency format display mode, with UTC Time display, without a time offset, the command would be;
\$GPGTC,0 UTC +0000T*
- Example 3: PPB frequency format display mode, with EST Time display, with a time offset of 5:00 hours, the command would be;
\$GPGTC,2 EST +0500T*
- **NOTE ! All basic command strings (\$) for programming need to be copied twice (2x) into the TX Send [field] of the Terminal Emulator (without a space between them). i.e. Copy \$GPGTC,0 GMT +0000T* twice for sending to the GPSDO as follows:
\$GPGTC,0 GMT +0000T*\$GPGTC,0 GMT +0000T* (two basic command strings as**
- After a command is sent and executed successfully, the device will return an 'OK' reply.
- When LCD display programming has been completed, remove the PC connection, and set the 'Test Mode Jumper' to the normal 'Run Mode' (Open). Recycle the GPSDO DC Power (OFF/ON), and the GPSDO should boot-up using the new LCD Display Option format.

4.7 Notes

The LCD display for the Frequency Standard's frequency, or error, is a calculated value, and as such, there may be a deviation from its actual frequency.

The GPSDO surface will become Warm (not HOT) during operation, and this is normal.

For optimum GPS signal Lock, place the antenna for a clear view of the sky, avoid potential interference sources such as high voltage power lines, etc. GPS Lock may be obtained without a full view of the sky, although with a potential for degradation in frequency accuracy.

Section 5: Block diagram

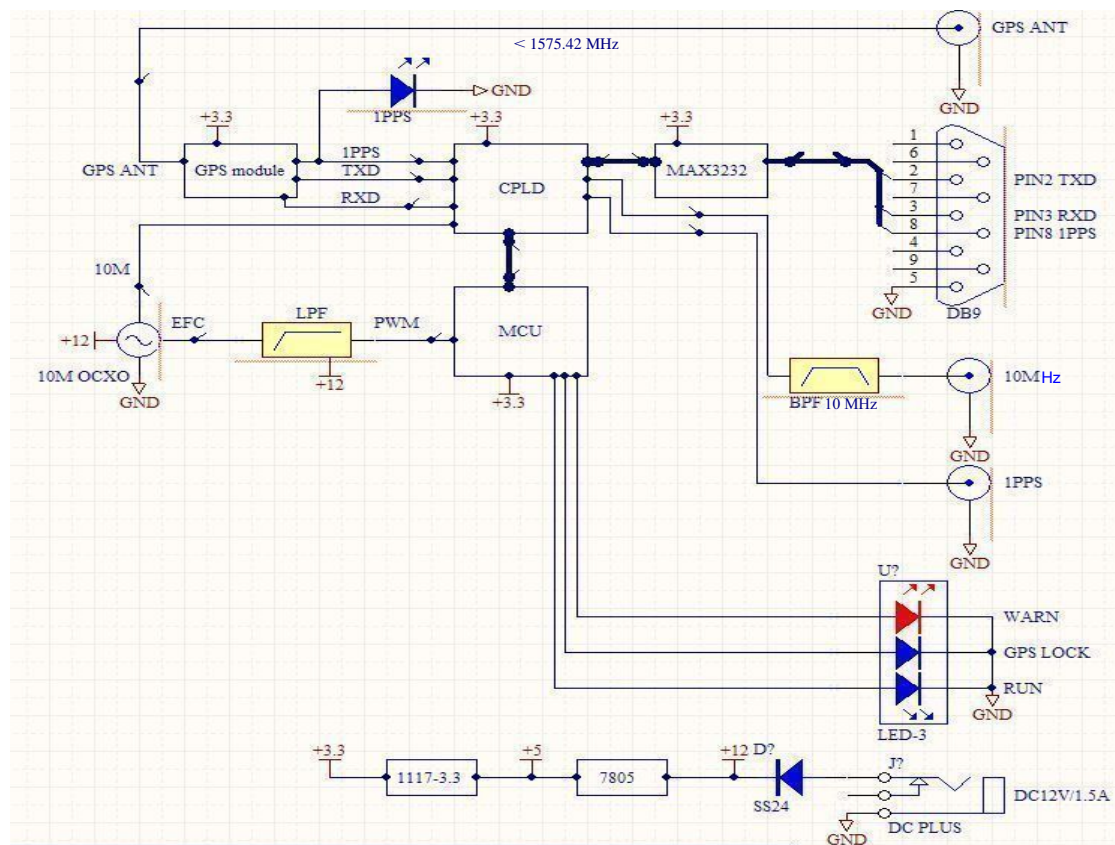

Block Diagram

Section 6: FAQ

Q : How can I tell if the device is working?

A : After powering ON for several minutes, the ALM (red) LED should turn off.

Q : How can I tell if the MCU is working?

A : When powered ON, all the LEDs will light momentarily, then the RUN (green) LED will be flashing, and the ALM (red) will be lit, indicating the MCU is operating.

Q : The 5m GPS active antenna cable is too short for connecting it to the GPSDO?

A : An appropriate 50 Ohm coax extension cable with SMA M/F connectors can be used. The GPSDO will operate in if the GSP antenna isn't connected, or the GPS signals are lost for any reason. In this event, GPS NO FIX is displayed, and the frequency accuracy may be degraded.

Q : I use a frequency counter and the frequency of the device shows a difference, what should I do?

A : The LCD frequency of the device is from a internal calculation, the actual test frequency may have a deviation. However, when the machine displays L10000000.0000 Hz the the accuracy is high. For verification measurement, ensure that the reference frequency measurement device's accuracy is at least good for +/- 0.000,01 Hz. A frequency counter should have an accuracy of at least 10 times better than the expectation of the device being measured.

Q : The displayed GPS signal strength changes from high, to low, etc.

A : Some of this is normal. The signal strength is affected by the satellite locations, weather (rain, snow, etc), and any signal absorption, or reflections.

